

US \$9.95  
GBP £6.55

# Testing High Voltage Breakers

A guide to understanding  
what is involved with  
keeping the lights on

**Megger** <sup>®</sup>

[WWW.MEGGER.COM/US](http://WWW.MEGGER.COM/US)

The word "Megger" is a registered trademark

<b>Introduction</b> .....	<b>2</b>	<b>Coil Current Measurements</b> .....	<b>9</b>
<b>Why Test Breakers?</b> .....	<b>3</b>	Travel Motion.....	9
<b>Bad things can happen</b> .....	<b>4</b>	Breaker Timing and SC Points .....	10
<b>Maintenance Strategies</b> .....	<b>5</b>	First Trip.....	11
<b>What to test</b> .....	<b>6</b>	<b>Working between the Grounds</b> .....	<b>11</b>
Timing Measurements.....	6	Vibration Testing.....	12
Coil Measurements .....	7	Test Method.....	12
Travel Measurements .....	7	<b>Failure Mode Analysis</b> .....	<b>14</b>
Minimum Trip Voltage.....	7	<b>After the Test: Data Interpretation</b> .....	<b>15</b>
Contact Resistance/Ductor .....	7	<b>Megger Test Instruments</b> .....	<b>16</b>
<b>What is Static Resistance?</b> .....	<b>7</b>	<b>How to Mount a Motion Transducer</b> .....	<b>17</b>
<b>What is Dynamic Resistance?</b> .....	<b>7</b>	<b>DRM (Dynamic Resistance Measurements)</b> .....	<b>19</b>
A Look Inside .....	7	<b>References</b> .....	<b>19</b>
Timing .....	8		

## INTRODUCTION

### What's in the name...?

For over 100 years, Megger has been a premier provider of test equipment and measuring instruments for electrical power applications. The Megger trademark was first registered in May 1903 and is closely guarded by the company. Although Megger is best known for its world-famous range of insulation testers, the company provides a full service solution to meet all electrical test and measurement needs. Megger products provide testing solutions for the most critical maintenance areas, including cable fault location, protective relay and circuit breaker testing, and power quality testing. With such a diverse product offering, Megger is the single source for electrical test and measuring instruments.

The Megger product offering spans 30 distinct product groups with over 1,000 specific products.

Circuit breaker test sets, watt-hour meter test equipment and protective relay test instruments, instruments used for testing and maintaining transformers, batteries and underground cables and other products designed for the power industry were formerly supplied under the Biddle, Multi-Amp, PAX Diagnostics and Programma brands. Among other innovations, Megger developed the first completely automatic, software driven protective relay test system in 1984 and the first commercial cable fault locator in 1950.

Manufacturing insulation testers from 1kV to 10kV is where Megger started, and the Megger brand name is so well known today that maintenance professionals often incorrectly use it as a verb when they refer to insulation testing on wiring. This famous name dates back to 1889, when the first portable insulation tester was introduced with the MEGGER brand.

Recently, Megger acquired PAX diagnostics, adding sweep frequency diagnostic test equipment to its portfolio. Megger enjoys an outstanding reputation in the areas of ground testing, oil testing and as a supplier of electrical contractor maintenance tools such as multimeters, portable appliance testers and clamp-on meters.

The most recent addition to the Megger product line is an innovative range of instruments for testing data and telecommunication installations. Working with both copper and optical technologies, and collaborating closely with the major industry players, Megger has developed easy-to-use products to keep the costs of test and measurement down and productivity up.

Megger also operates the renowned AVO Training Institute, which offers top rated training for electrical maintenance and safety through the network of Megger offices. In addition, the company manufactures STATES® terminal blocks and test switches, which are specified by many major electric utilities. For over 65 years, test technicians and engineers have depended on STATES products to provide easy access to wiring on panel boards and switchboards, to eliminate wiring reconnection errors and to save operator time.

Megger manufactures and markets products on a global scale. Its principal manufacturing sites are in College Station and Dallas, Texas; Valley Forge, Pennsylvania, Dover, England and Täby, Sweden. Sales and technical support offices are maintained at each manufacturing site as well as in Sydney, Australia; Toronto, Canada; Paris, France; Oberursel, Germany; Mumbai, India, Johannesburg, South Africa; Oberkum, Switzerland, Chonburi, Thailand and Bahrain, UAE. With a global network of hundreds of sales representatives, product literature and user manuals in eight languages, and multilingual product software, Megger is a local supplier for customers anywhere in the world.

All Megger products meet the highest standards for quality, reliability and safety. All of the company's facilities are certified as meeting the requirements of the ISO 9001 quality standard, and the Dover and Täby sites are also certified to ISO14001, the international environmental standard. Megger is constantly striving to maximize quality, thereby ensuring that the experience of its customers is always world class.

### WHO SHOULD READ THIS DOCUMENT?

This document is intended for engineers and technicians in the power, industrial and utility sectors who wish to learn how to test substation circuit breakers.

## WHY TEST BREAKERS

Some of the most important of the many reasons for testing circuit breakers are:

- To guard against damage to expensive equipment
- To prevent outages that lead to loss of income
- To ensure reliability of the electricity supply
- To prevent downtime and darkness
- To verify breaker performance

Substation breaker testing is an important task for any utility. The breakers are there to facilitate the flow of current during normal operation and to interrupt current flow in the event of a fault. But any and all electrically operated devices are, sooner or later, likely to experience some kind of failure. That failure can be caused by many factors, including ageing and external faults. The utility operator has to be prepared and have a plan in place to handle every situation.

This document will help readers to understand what is involved with keeping circuit breakers operating at peak performance. Breakers are mechanically challenging devices requiring periodic adjustments. The need for some of these adjustments can be determined visually and they can be given the attention needed without testing. However, in most cases, it will be necessary to carry out electrical testing to find out what is the cause of out-of-tolerance conditions.

This document primarily deals with electrical testing.

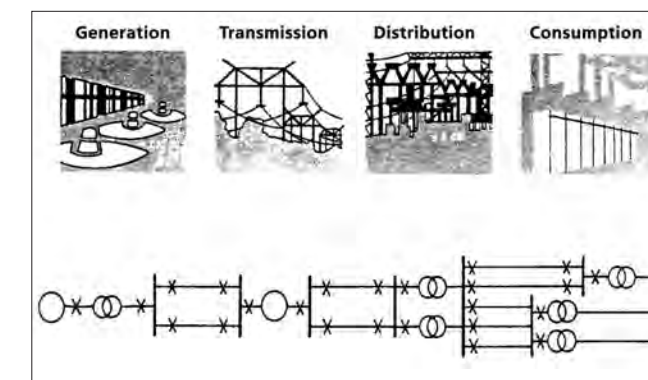

HV Breakers in a transmission scheme can be viewed as forming a tree starting with the generating station, fanning out to the transmission grid, to the distribution grid, and finally to the point of consumption.

The task of the utility is to generate power, transmit it and distribute it with maximum availability. While doing this, it is imperative that losses are kept to a minimum, and acceptable levels of power quality and safety are maintained. All of this must be done in an environmentally friendly manner. Breakers play an important part in making this happen.

High voltage circuit breakers are extremely important for the function of modern electric power supply systems. The breaker is the active link that ultimately has the role of quickly opening the primary circuit when a fault occurs. Often, the breaker has to perform its duty within a few milliseconds, after months, perhaps years of idly standing by. Since RCM (reliability centered maintenance) and condition based maintenance have become the established strategies for most owners and operators of electric power delivery systems, the need for reliable and accurate test instruments for field use is clear.

Protection systems are put in place to detect all electrical faults or other abnormal operating conditions and they are coordinated to disconnect the smallest possible part of a power system in the event of a fault. With good system design, it should be possible to quickly restore normal operation.

When a fault is detected by a protective relay and a trip impulse is sent to the breaker operating mechanism, the breaker has to function as specified and interrupt the current as soon as possible or severe damage may occur. The cost of damage caused by a malfunctioning breaker can often reach millions of dollars.

Proper functioning of a breaker is reliant on a number of individual components that have to be calibrated and tested at regular intervals. The trigger for maintenance intervals differs greatly between utilities but the intervals are often based on time since last test, number of operations, or severity of fault current operations. Environmental considerations such as humidity and temperature, whether the breaker is located in a desert or coastal region, also play into the maintenance scheme.

Mechanical wear and lubrication often affects the performance of breakers, so being able to trend mission critical parameters and compare these with factory thresholds helps to verify proper breaker functionality.

## BAD THINGS CAN HAPPEN – SAFETY FIRST!

There are many things to consider when testing a HV Breaker, but first and foremost, it is essential to think about safety. Always:

- Make sure the breaker is isolated and grounded
- Disconnect the breaker control circuit from test equipment before performing work on the breaker
- Observe polarity
- Use touch-proof connectors
- Connect the ground to the test equipment
- Comply with local safety regulations
- Exercise care before operating a breaker

As with any electromechanical device, things can happen that cause problems in the substation. The mantra of most utilities is “Thou shall not fail to trip” when talking about the breakers.

But ensuring that the breaker will operate when needed requires maintenance. Testing is essential.

It is not always an electrical failure that causes a breaker to trip, as the following examples show.

1) Animals can get across the hot line of a breaker and cause an unexpected trip, as can be seen in the photo below where a snake got across a live conductor and ground.



2) There was a ground fault a few years ago that caused the insulating oil inside a transformer to evaporate and finally it caught fire. The upstream breaker should have cleared this fault, but it was too late.

3) In Ohio, thieves removed the ground conductors in a substation. This resulted in a fire that was put out before it caused major damage, but it could have easily led to a disaster had it not been caught in time.



4) Even in a substation with batteries controlling the operation of the trip coils on breakers, there can be failures.



According to a recent study, the following were the most commonly reported breaker problems:

<b>Does not close on command</b>	<b>34%</b>
<b>Does not open on command</b>	<b>14%</b>
<b>Breakdowns (poles, ground)</b>	<b>8%</b>
<b>Operates without command</b>	<b>7%</b>
<b>Others</b>	<b>30+%</b>

(Courtesy CIGRE)

The same study listed the most common fault areas as:

<b>Operating mechanism</b>	<b>70%</b>
<b>Interrupters</b>	<b>14%</b>
<b>Insulation</b>	<b>6%</b>
<b>Frame/foundation</b>	<b>5%</b>
<b>All others</b>	<b>5%</b>

(Courtesy CIGRE)

With some breakers, it is also useful to look at the frequency of operation when determining the maintenance strategy.

For example:

<b>No of operations</b>	<b>&gt;10,000</b>
<b>Time</b>	<b>&gt;20 years</b>

Actual service, number of operations

<b>Line CBs</b>	<b>&lt;50/yea</b>
<b>Generator CBs</b>	<b>&lt;1/day</b>
<b>Filter CBs</b>	<b>&gt;1/day</b>

## MAINTENANCE STRATEGIES

Various utilities, people and organizations have different viewpoints on and approaches to maintenance strategies. Testing and maintenance methodologies have changed over the years and in all likelihood will continue to evolve as new technologies become available. This section is only intended to create awareness about some of the possible approaches. There are no correct or incorrect strategies, but there is sometimes a better way of doing things.

Approaches to maintenance include but are not limited to the following:

- Corrective maintenance
- Preventative maintenance
- Periodic time interval based maintenance
- Condition based maintenance
- Reliability centered maintenance (The primary aim here is to preserve system functions by determining the criticality of individual components, etc.)

Whatever form of maintenance approach is selected, the most important goal is to **achieve maximum reliability at the lowest possible life cycle cost**. The bottom line is usually **\$\$\$\$ but do not forget personal safety!**

Ideally a non-invasive method of testing should be used; with Megger equipment it is possible to compare measured values of key parameters with the values that are given by the circuit breaker manufacturer. A series of tests are carried out to provide a comparison with previous results or to create a “footprint” for future reference and comparison. Where changes are discovered, further tests and analysis can be carried out to trace the cause of deviations from the reference and to determine corrective action.

### Corrective Maintenance

- when something has already happened

### Preventive Maintenance

- based on time or number of operations

### Periodic Maintenance

- carried out at regular intervals

### Condition-Based Maintenance

- a maintenance flag is set

### Predictive Maintenance

- service only when needed

### Reliability Centered Maintenance

- predictive maintenance but with value/importance priorities taken into consideration

No matter which strategy is chosen, it is important to strive to have the same conditions from test to test. High precision signal acquisition is also necessary, together with high measurement accuracy and a reliable means of storage for data.

If the set up work required can be minimized and the connection hook-up from the test instrument to the apparatus simplified, faster testing and evaluation of results can be achieved.

Testing can be done at various stages in the life of a breaker including:

- Development
- Production
- Commissioning
- Maintenance/fault tracing
- After service (re-commissioning)

Most breaker failures are due to lack of maintenance.

The three important issues for breaker maintenance are:

- Lubrication
- Contact Adjustment
- Neglect or lack of maintenance

Briefly, the most important thing for breaker maintenance is grease. ALL breakers use grease as lubricant, and grease tends to dry out over time. Heat is produced on the breaker parts as the breaker carries its normal load current and that heat dries out the grease.

Most breaker manufacturers allow the use of Mobil 28 lubricant, but you should check with the breaker manufacturer for their specifications. An important thing to keep in mind is NEVER to use WD-40. It has a tendency to evaporate rather quickly leaving moving surfaces without lubricant.

Further details of that type of maintenance will be left for another presentation. This document will continue by discussing non-invasive functional testing.

Maintenance and inspection procedures can include any or all of the following:

#### Test Equipment

- Micro-ohmmeters
- Breaker analyzers
- Power supplies
- Vacuum testers
- High current sources

#### Software – including capability to do the following

- Set user defined parameters
- Create databases
- Generate reports
- Analyze data
- Create graphical presentations

## WHAT TO TEST

### Definitions

There are fundamental differences between timing, travel, motion, velocity, and acceleration. The differences need to be explained before going any further.

### Timing

Timing is most often measured in milliseconds (ms) but it is occasionally measured in cycles. Note the value of a cycle is different depending on what region of the world you are in i.e. 50Hz or 60Hz network.

### Close Time

The time it takes from the moment a circuit breaker receives a close pulse until the main contact touches.

### Open Time

The time it takes from the moment a circuit breaker receives an open pulse until the main contact separates. This is also referred to as Trip Time.

### Close-Open Time

The time it takes from the initial touch of the main contact until the main contact separates. This is commonly referred to as Trip-Free Time or Contact Dwell Time.

### Open-Close Time

The time it takes from contact separation until the contact touches again. This is often referred to as Reclose time.

### Travel

The travel trace indicates the instantaneous position of the circuit breaker contacts during an operation. The travel trace is a bi-directional linear movement traveling back and forth between the open and closed positions. Travel is measured in either millimeters or inches.

### Velocity

Measured in meters per second (m/s) or feet per second (ft/s) velocity is calculated from the slope of the travel trace. This is the speed at which the main contacts travel.

### Acceleration

This is the rate of change of velocity of the contacts.

Electrical testing can reveal much information about the health of the High Voltage Breaker.

There are several electrical parameters that need to be tested on these breakers including the following:

### Timing Measurements

Timing of the contacts can include the main contacts, pre-insertion or post-insertion resistors, and auxiliary contacts. Timing of the contacts can be as simple as a single break per phase or as complicated as 12-breaks per phase.

## Coil Measurements

Coil measurements can be recorded on both close and trip coils. If the breaker is gang operated then you will have one trip coil and one close coil operating all three phases. If the breaker is an IPO (Independent Pole Operation) breaker then you will have a separate close coil for each phase and a separate open coil for each phase.

### Travel Measurements

Travel measurements include stroke, speed, damping, and penetration of the main contacts.

### Minimum Trip Voltage

Under normal conditions the breaker should be operated at a standard control voltage but the breaker is designed to operate at a minimum voltage level as well. This test will allow the operator to verify that the breaker coil is operating correctly by injecting a variable coil voltage and observing whether the breaker maintains proper trip characteristics within acceptable levels of control voltage.

### Contact Resistance/Ductor

Contact resistance tests provide information about how healthy the contacts are and their ability to handle their rated current. The maximum contact resistance should be verified against manufacturers' specifications.

Rated current should not be exceeded and testing at 10% of the rated current is recommended. The minimum DC test current should be used according to manufactures specification; however, the IEC and ANSI recommended levels are:

50 A	IEC 60694
100 A	ANSI

Contact resistance tests are commonly referred to as a Ductor, micro-ohmmeter, static resistance test or DLRO which stands for Digital Low Resistance Ohm Meter. Static Contact resistance is measured by injecting a DC current through the breaker or device under test and measuring the voltage drop. A four wire measurement method is used. The breaker must be in the closed position.

Static resistance is measured to reduce switchgear breakdowns caused by high contact resistances across bus bar joints, breaker contact points and isolators.

If low resistance readings are obtained when testing the breaker contact resistance using a low current, then it is recommended to re-test the contacts at a higher current. Why would we benefit using a higher current? A higher current will have the ability to overcome connection issues and oxidation on terminals, where a lower current may produce false (higher) readings under these conditions.

## WHAT IS STATIC RESISTANCE

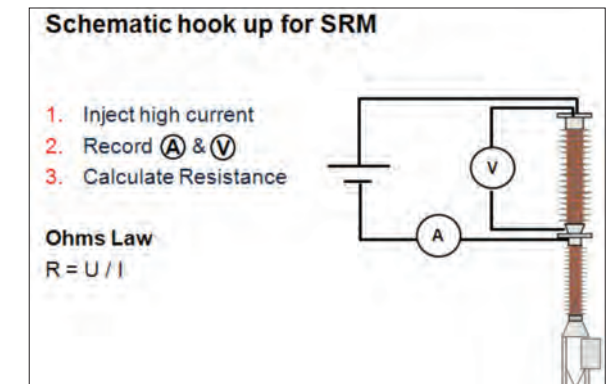

High contact resistance in circuit breakers is caused by high-current breaking operations. Modern networks are carrying increasing loads requiring improved contact resistance.

### Potential problems that can be detected:

- Overheating of contact surfaces
- Internal breakage (even with a breaker in the fully closed position the resistance is infinite)

## WHAT IS DYNAMIC RESISTANCE?

### A look inside

Here is a cut-away view of the inside of an Arcing Chamber of an SF<sub>6</sub> Breaker.

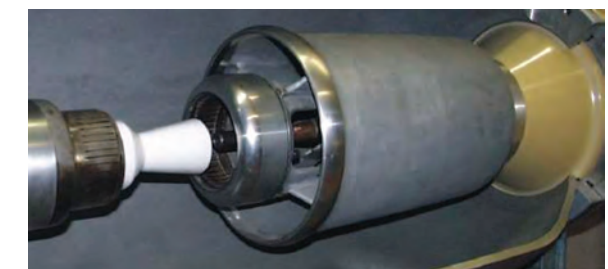

The white nozzle is the Arc Chute for the arcing contact. The right side of the picture is the stationary part of the contact and the left side with the white nozzle is the moving contact. The arcing contact is the metal rod (copper, tungsten, etc.) that is inserted into the nozzle and is designed to take the brunt of the arcing during close and open operations. The ring around the arcing contact is the main contact (silver, silver plated copper, etc.) and it functions to carry the load while the breaker is in the closed position.

The arcing contact is the first to make contact during a close operation and the last to break contact during an open operation. The arcing contact wears by normal operation as well as when breaking short-circuit currents. If the arcing contact is too short or otherwise in bad condition, then the breaker soon becomes unreliable. Main contact surfaces can

be deteriorated by arcing resulting in increased resistance, excessive heating and in worst-case explosion.

The main contact resistance is measured dynamically over an open or close operation and the arcing contact length can be reliably estimated. The only real alternative in finding the length of the arcing contact is dismantling the circuit breakers arcing chamber.

Reliable interpretation requires high test current and a circuit breaker analyzer with good measurement resolution.

Dynamic resistance measurement, commonly known as “DRM” is a test method used as a diagnostic and analysis tool. It is a comparative test and as such will not necessarily yield results the first time it is performed. The measurement is performed by injecting current through the breaker and simultaneously monitoring the voltage drop as well as current flow during the operation of the breaker. From these two parameters a resistance value can be calculated. In the figure below the resistance trace starts out as a straight line before the breaker starts to move, this is your DLRO value. As the breaker starts to move, the resistance increases slightly. When the main contacts part, there is a spike in the resistance curve and now the arcing contact resistance can be measured. When the resistance goes to infinity or current flow stops the breaker is open.

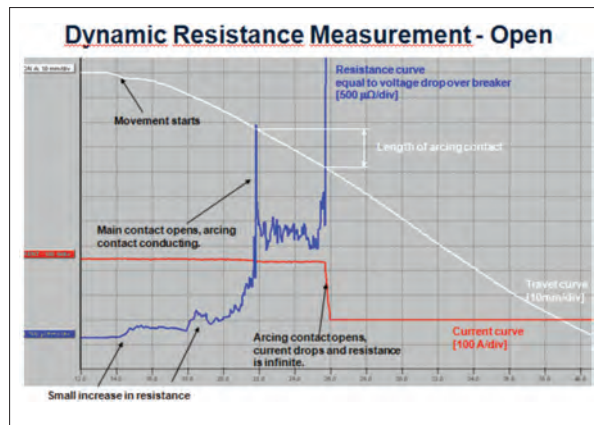

When a motion trace is overlaid onto the resistance trace, the actual length of the arcing contact can be determined. Monitoring the length of the arcing contact and the resistance of the arcing contact can give you insight into the health of the interrupter without opening up the breaker.

DRM can also be used as a timing measurement in certain applications when it is not possible to disconnect both sides of ground connections to the breaker.

**Potential problems to detect:**

- Measure shortening of the arcing contacts
- Determination of the length of the arcing contact
- Increased resistance of arcing contact

**Timing**

**Accuracy and Consistency** Variations in times obtained do not always indicate problems on the breaker. It’s important to take into account variations in ambient temperature, previous method of testing and the type of equipment used.

**Timing – within single phases** Simultaneous measurements within a single phase are important in situations where a number of contacts are connected in series. Here, the breaker becomes a voltage divider when it opens a circuit. If the time differences are too great, the voltage becomes too high across one contact, and the tolerance for most types of breakers is less than 2 ms.

**Timing between phases** The upper limits of timing between phases is approximately 5-7 ms, provided that the breaker is not equipped with synchronized tripping. Always consult the manufactures specifications when setting limits.

**Timing main/auxiliary contacts**

Circuit breakers use auxiliary contacts to determine what state the breaker is in and to control current flow in the control circuitry. Circuit breakers have two types of auxiliary contacts, “a” contacts and “b” contacts. The “a” contacts, which are found in the open control circuitry, follow the state of the breaker i.e. if the breaker is closed, the “a” contacts are closed and if the breaker is open, the “a” contacts are open. The “b” contacts, which are found in the close control circuitry, have the opposite state of the breaker i.e. when the breaker is closed, the “b” contacts are open and when the breaker is open, the “b” contacts are closed. The auxiliary contacts always lag the main contacts of the circuit breaker. As an example let’s discuss an open operation for the circuit breaker. The breaker starts in the closed position therefore the “a” contacts are closed and the “b” contacts are open. An open pulse is sent through the control circuitry and is flowing through the “a” contacts. The coil is energized and it releases the trip latch that releases the spring energy in order to trip the breaker. Once the breaker changes to the open state, the

auxiliary contacts quickly change state as well. When the “a” contacts switch from closed to open position, the coil is no longer being energized and it quickly discharges. There are no generalized time limits for the time relationships between main and auxiliary contacts, but it is still important to understand and check their operation.

**Potential problems that can be detected**

Closing times in spring-actuated breakers are directly related to the potential energy in the spring mechanism. Increasing or decreasing operating times tends to indicate changes in the amount of energy used by the linkage driving the main and auxiliary contacts. Increased friction will consume part of the spring’s energy. Time differences between phases with separate operating mechanisms could indicate differences in individual operating mechanism settings, imminent mechanism failure, internal chamber faults developing on a particular phase or be an indication of faulty actuating coils on a particular mechanism. Time differences between phases with a common operating mechanism could indicate internal faults on main and/or secondary contacts on a particular phase.

**COIL CURRENT MEASUREMENTS**

Please refer to Figure 1

**General**

Coil current measurement is a good diagnostic measurement tool to detect potential electrical and/or mechanical problems in the actuating coils. Specific parts of the mechanism that will be checked are the trip coil, the close coil and the auxiliary contacts.

**Time t0**

Time t0 is the time when the operating voltage is applied to the coil. If the voltage is temporarily interrupted for some reason, for example a bouncing contact in the supply source, the coil will be de-energized and the coil current will drop. As a result the operating time of the breaker will be increased due to uncontrolled fluctuations in the test device.

**Time t1**

Time t1 is the time when the latch of the coil begins to move. As a result the rate of rise of the current will change due to the change of inductance in the circuit.

**Time t2**

Time t2 is the time when the latch has stopped moving or slightly later. If the drop off of the current has been sharp as a result of a fast moving latch, the dynamic delay of the current drop might cause a minor delay in time t2 in comparison with the stop time of the latch.

**Time t2 to t3**

The rate of rise of current between t2 and t3 depends on the electrical characteristics of the coil.

**Time t4**

At time t4 the auxiliary contact breaks the DC supply to the coil, which de-energizes down to zero.

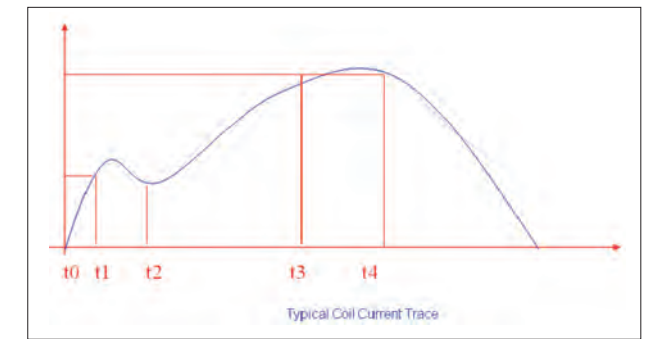

Figure 1.

The peak value of the first, lower current peak is related to the fully saturated coil current (max current), and this relationship gives an indication of the spread to the lowest tripping voltage. If the coil were to reach its maximum current before the armature and latch started to move, the breaker would not be tripped. It is important to note, however, that the relationship between the two current peaks varies, particularly with temperature. This also applies to the lowest tripping voltage.

**Travel Motion**

A high-voltage breaker is designed to interrupt short-circuit current in a controlled manner. This puts great demands on the mechanical performance of all components in the interrupter chamber as well as the operating mechanism. It has to operate at a specific speed in order to build up adequate pressure to allow for cooling stream of air, oil or gas (depending on the type of breaker) to extinguish the arc that is generated after the contact separation until the next zero-crossing. It is important to interrupt the current to prevent a re-strike. This is accomplished by making sure that the contacts move apart far enough from each other before the moving contact has entered the so-called damping zone.

The contact travel motion is captured by connecting a travel transducer on the moving part of the operating mechanism. The motion is presented as a curve where distance vs. time allows for further analysis. Speed is calculated between two points on this motion curve. The upper point is defined as a distance in length, degrees or percentage of movement from

a) the breaker's closed position, or b) the contact-closure or contact-separation point. The time that elapses between these two points ranges from 10 to 20 ms, which corresponds to 1-2 zero-crossovers.

The distance the breaker has to travel in which the electric arc must be extinguished is usually called the arcing zone. From the motion curve, a velocity or acceleration curve can be calculated in order to reveal changes in the breaker mechanics that may affect the breakers operation.

Damping is an important parameter to monitor and test as the stored energy an operating mechanism use to open and close a circuit breaker is considerable. The powerful mechanical stress can easily damage the breaker and/or reduce the breakers' useful life. The damping of opening operations is usually measured as a second speed, but it can also be based on the time that elapses between two points just above the breaker's open position.

**The Travel Trace**

By analyzing the travel trace obtained from a linear or rotary transducer it is possible to obtain information about the contacts such as total travel, over travel, rebound, under travel, contact penetration, and contact position at the time of making or breaking. See the following graph for a typical "close" travel trace.

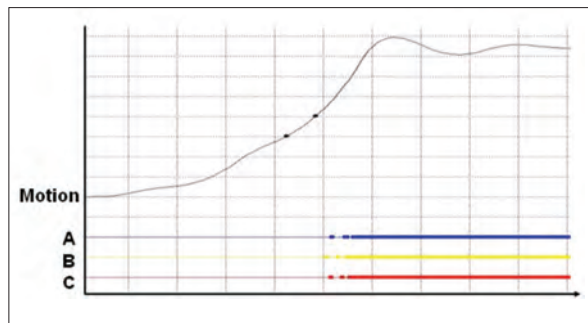

**Speed**

Manufacturers often include speed calculation points in their breaker specifications. These are predefined points of reference, which we can use with the breaker analyzer to determine a velocity in a certain region on the travel trace. These points will be used as the speed calculation points asked for in the CABA software. Speed is defined as the "average speed calculated between two defined points on the motion curve. A point might be defined as an absolute position, an absolute time, a position at the instant for an event, a time difference or position difference to the other point."

**Breaker Timing and Speed Calculation Points**

I was helping a customer who was using a TM1600 Breaker Timer to time an old McGraw Edison OCB. He was getting good contact timing information of 20 ms closing time for phase A, but he was not getting any speed information.

We did not know what the SC (speed calculation) points were for the breaker but he did tell me that he had a stroke of 355 mm. He had his "Cls Sp Calculation Blw Cls" point set to 1.97 inches. I told him to make that value 4 inches and it started working. The reason is that we moved the point down onto the linear portion of the curve. The original value was too close to the end of the travel, so the motion was over before the TM1600 could calculate the speed. By moving that point down, it was able to calculate the speed correctly.

Below is a typical printout from a TM1600 Breaker Analyzer.

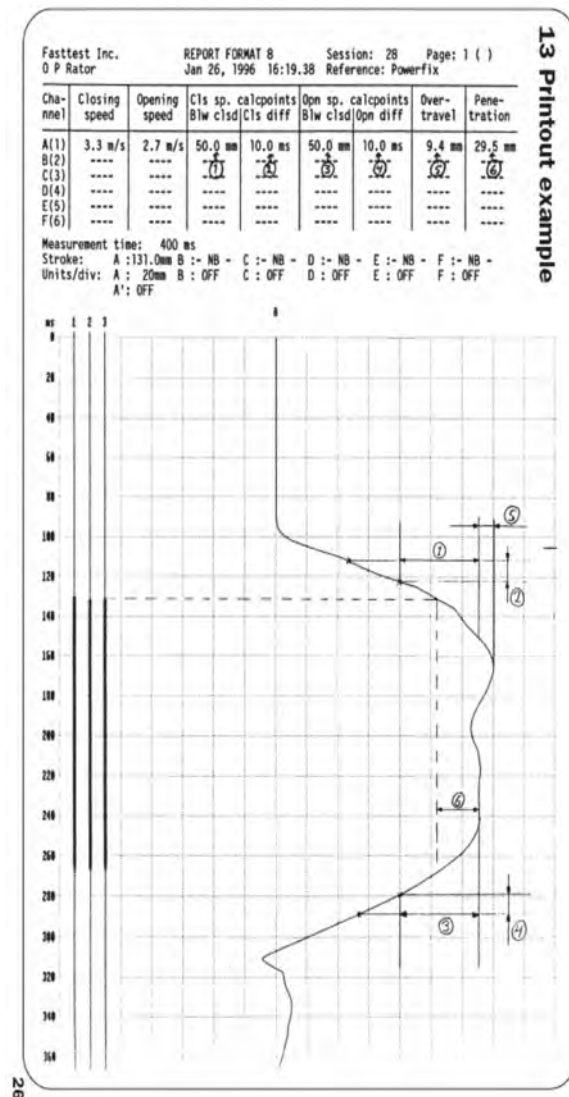

**First trip**

Testing the circuit breaker's first open operation after it has been sitting idle for some time, is a good way to evaluate status, especially of a line circuit breaker. The measurement and connections to the circuit breaker are carried out while it is still in service. All of the connections are made inside the control cabinet. This of course makes it impossible to do some of the recordings and means that there is a bigger risk of injury during testing. Extra caution must be taken since there is up to 480V in the control cabinet and the mechanism is fully charged. The breaker can operate at any time if there is a fault on the line.

The biggest benefit of using first trip testing is to test "real world" operating conditions. If the circuit breaker has not operated for year, first trip testing will show if the circuit breaker is slower due to problems like corrosion in the mechanism linkages. With traditional methods, the testing is carried out after the circuit breaker has been taken out of service and has been operated once or even twice.

On a gang operated breaker once coil current is measured and on an IPO breaker three coil currents are measured. Auxiliary contacts can also be measured. If the CB has another breaker connected in parallel then open times may also be measured by monitoring the protection CT's. A more advanced approach to first trip is to also measure vibration. This provides detailed information of the status of the circuit breaker. These measurements during first trip are possible with TM1800 and TM1600/MA.

**WORKING BETWEEN THE GROUNDS**

**Dual Ground Testing Significance**

With the ongoing deregulation of the electrical power industry, utilities and service companies are acting in a changing business environment. There is expectation of increasing profitability with fewer and fewer key technical resources. Further, companies are judged by the public on their social activities. The health and safety of personnel undertaking high voltage testing has become a topic where trade unions and media are on their toes at a time when the level of critical skills is decreasing. Stock price can be significantly impacted by poor health and safety performance – never mind corporate responsibility laws that could put senior managers in court for negligence. Keeping HV test engineers safe has never been more important.



Regulations and laws require all objects to be grounded on both sides of a breaker before any maintenance work is performed on the object. The average experience of personnel for substation testing has seen a decrease in recent years. The education level and experience reduction of personnel lead to an inability to follow complex safety procedures and requires extensive field training or can lead to uncertainty that tests are being executed in a correct way. Electric arc flash and electrocution accidents in substations are due to fault currents, lightning on power lines connected to the substation and capacitive coupling within the substation. The outcome of accidents spans from short-term hospital visits to funerals. This risk appears because a test on the circuit breaker is performed without safety grounding. The risk for an accident can be regarded as low, but the impact could be catastrophic and usually covered by media. Arc flash accidents in high voltage substations will cause significant injuries. The most important test for circuit breaker diagnosis is the main contact timing and contact resistance. Main contact timing and contact resistance requires an instrument connected to the circuit breaker on site. Knowledge of conventional instrumentation technology implies that safety grounding can be removed during the test and is therefore not in compliance with national law, trade union demands, or substation safety procedures produced by standardization bodies like IEEE and IEC. Safety bodies, like HSE and OSHA and their counterparts in other countries have guidelines prescribing that circuit breakers need to be grounded at both ends during any maintenance work. The current situation is mitigated by undertaking cumbersome and time-consuming safety procedures. This makes the test work very inefficient from a personnel and asset management point of view. Because the safety ground is removed, extensive safety exercises are added to the way of working. A special work permit has to be acquired in the field and this is typically granted by remote office personnel.

### DualGround Testing Has Arrived!

Dual grounding involves grounding the breaker on both sides after it has been removed or taken out of service. When HV breakers in live substations are removed from the system, the effects of the induction from adjacent live overhead lines can create hazardous voltages in any un-grounded equipment and erroneous results in connected test equipment. Typical substation procedure includes the breaker being grounded on both sides initially and then one side is usually removed or temporarily lifted while testing is taking place. The DualGround technology allows the breaker under test to be grounded while testing is being performed without any impact to the test results being obtained.

#### Benefits

There are various benefits to using DualGround capable test Instruments:

- Personnel can work safely between safety grounds
- Test results are not affected
- No need for a standby bucket truck and crew
- No waiting time between tests
- Hazardous voltages are negated
- Number of work permits is reduced
- Actual testing time is reduced

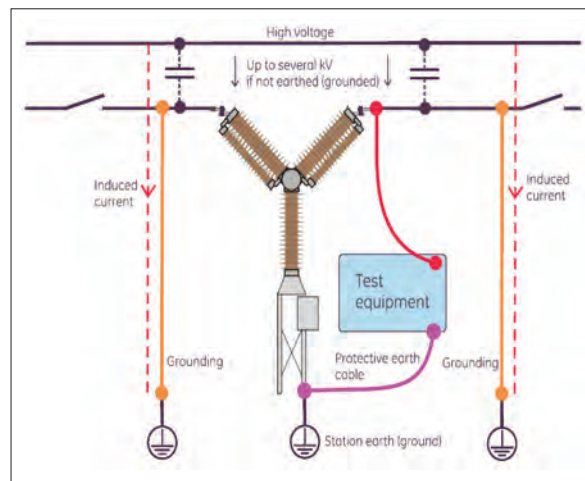

Figure 2. Connection diagram of TM1800 with both sides grounded.

### VIBRATION TESTING

Many different diagnostic methods have been used over the years. The most common measurements on circuit breakers are off-line measurements of contact resistance, contact timing, travel motion, velocity and coil current.

More sophisticated methods are acceleration, DRM (dynamic resistance measurement) and vibration testing. The tests are well known and widely used for periodic or preventive maintenance.

Another possibility is to introduce on-line condition monitoring of circuit breakers. An estimated 10% of breaker problems and failures are attributed to improper maintenance, and condition monitoring could possibly eliminate too-early or unnecessary off-line testing and overhauls and make just-in-time maintenance possible. The problem is that a complete monitoring system that covers all breaker subsystems and failure modes can easily escalate in complexity until its cost becomes as much as half the breaker cost.

An alternative to installing a separate condition monitoring system on each breaker is to use portable test sets but still perform in-service measurements on energized breakers. The complete test procedure will be less complex and the time saving may be substantial compared to traditional off-line testing. To many utilities, this may become an attractive testing alternative.

#### TEST METHOD

Traditional circuit breaker testing is based on measuring specific parameters like close/open time, contact speed, maximum coil current, and then comparing the test data with the specifications from the manufacturer (pass-fail testing). When using more advanced circuit breaker analyzers and/or test methods, such as dynamic resistance and vibration testing, it is also possible or even necessary to look at the different waveforms as unique signatures or footprints for the individual breaker. This approach may also be used when measuring a circuit breaker in-service, on line and under load.

It is important to understand that the signature data are not precise single-numbered values for a pass-fail decision. Instead the signature should be used for comparisons with benchmarks, ideally taken from the very same breaker or at least from the same circuit breaker type. Comparing signatures by using overlays has proved to be a reliable method of detecting critical changes in breaker performance.

The following parameters can be measured with the in-service test:

#### Trip and close coil currents

The trip and close coil current measurements reveal a lot of interesting data such as maximum current, latch release time and current interruption time. The current waveform for the individual breaker is unique and a good indicator of circuit breaker performance.

#### Auxiliary (A/B) contact timing

As in many condition-monitoring systems, the auxiliary contacts can be used as an indirect measurement of the main contact. The switching times of the "a" and "b" contacts are correlated to the main contact timing and, depending on the actual design of the breaker, the statistical deviation between the two may be very small. Within the limitations of the breaker design, the a/b contact time provides an accurate and repeatable reference for the main contact timing.

#### Load current/Main contact timing

Using the secondary current from the circuit breaker current measurement transformer, it is possible to measure the load current using a Hall-effect clamp on current sensor. From the waveform and depending on the actual test setup, both contact closing and opening may be detected as well as when arcing is extinguished.

#### DC voltage supply

Proper breaker operation is only achieved if the supply voltage to the operating coils is stable at the correct value. Monitoring the DC voltage when operating the breaker gives a quick test of the battery system, including wiring and junctions from the batteries to the circuit breaker.

#### Vibration

Vibration testing of circuit breakers is an interesting tool for circuit breaker diagnostics. In particular, measurements inside the operating mechanism have given the best input data for the analysis. This means that in-service testing using vibration data for diagnostic comparisons can be a very useful tool.

When a breaker operates, the mechanical motion generates strong vibrations. These signals can be used for diagnostics and maintenance. Both TM1600/MA and the popular TM1800 can make vibration measurements.

One or more accelerometers are attached to the breaker poles and operating mechanism. Vibration signals from the accelerometers proceed via a signal-conditioning unit that incorporates an amplifier and filter to the TM1800 or TM1600/

MA61 where they are recorded during breaker operation. The directly recorded vibration signals can be analyzed in the CABA Win program, together with time, motion and coil-current data. These data alone, however, do not suffice for determining breaker-condition trends.



#### Typical Accelerometer

A sophisticated procedure known as dynamic time warping (DTW) is used for further analysis. DTW compares vibration signals with reference signals obtained (preferably) from a previous test conducted on the very same breaker. However, inter-phase comparisons and comparisons with the results of tests conducted on other breakers of the same type can be used in the initial phase of a series of tests. Comparison results are presented on a time-time diagram that shows time deviations and also on a deviation diagram that reveals differences in vibration amplitudes.

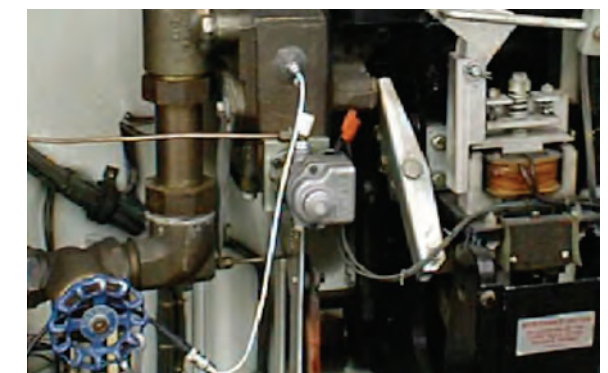

All test data and analysis data can be reported along with other data such as motion and speed. The overall results provide a more detailed picture of breaker condition than has previously been available. In this picture it is easily possible to discern deviations that are beginning to appear and trace their origins.

DTW vibration analysis is available in a separate program module that can be purchased as an optional add-on for CABA Win. This type of measurement requires a high sampling rate and a broad dynamic range. Together with the specially designed signal conditioning amplifier SCA606, the TM1600/MA61 or TM1800 enables users to measure vibrations with frequencies ranging up to 15 kHz.

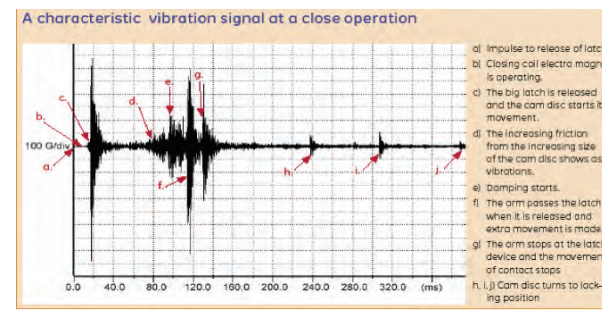

**FAILURE MODE ANALYSIS**

The following chart indicates some typical failure modes of HV Breakers and looks at the various mechanical areas that could cause an out-of-tolerance condition.

Close Time	Open Time	Damping Time	Charging Motor	Possible cause of failure condition
Faster/ Slower	Normal	Normal	Normal	Change in characteristic of the closing system. Latching system is binding.
Faster	Normal	Normal	Normal	Spring charging system used for closing is damaged. The springs have probably been excessively charged, and the breaker has been operated.
Slower	Normal	Normal	Normal	Spring charging system used for closing is damaged. The springs have probably been excessively charged, and the breaker has been operated.
Normal	Slower	Normal	Normal	Change in characteristic of the closing system. Latching system is binding.
Faster	Slower	Normal / Slower	Normal / Slower	Reduced force exerted by opening springs. One of the opening springs is broken.
Slower	Slower	Normal / Slower	Normal / Slower	Increased friction throughout the entire breaker caused by (for example) corrosion in the linkage system.
Normal	Faster	Normal	Normal	Malfunctioning puffer system or extremely low SF <sub>6</sub> - pressure.
Normal	Normal	Faster	Faster	Damaged opening damper. Not enough oil in the dashpot.
Normal	Normal	Slower	Slower	Damaged opening damper. Increased friction in the dashpot.

**AFTER THE TEST: DATA INTERPRETATION**

With any complicated procedure like HV breaker testing, it's important to have a good software package to store and analyze the data. For this, Megger offers a product called CABA Win (Computer Aided Breaker Analysis for Windows).

After connecting the breaker analyzer to a personal computer (PC), CABA Win can be used to speed up testing and improve reliability. CABA Win can be used with TM1800, TM1600/MA61 and EGIL. Results are presented on the display both graphically and in table form after each breaker operation so that comparisons can be made with limit values and previous test results from any of the three analyzers. Simple procedures enable the creation of individual test plans tailored to individual breakers. Timesaving conversion tables simplify the task of connecting and linking transducers to the breaker. Reports created in the user's own format can be obtained easily using standard field-linking functions in List & Label or Microsoft Word. The reports are easy distributed either in the form of a pdf document or in List & Label format which can be read by a freeware L&L viewer. A basic database is included in the program to help users to organize their circuit breakers.

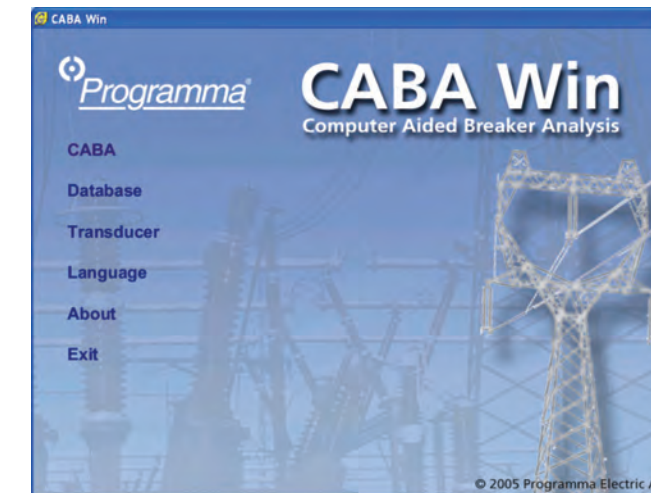

CABA Win's intuitive split screen format means that users can easily navigate to past test data or quickly create a new test to gather new test data.

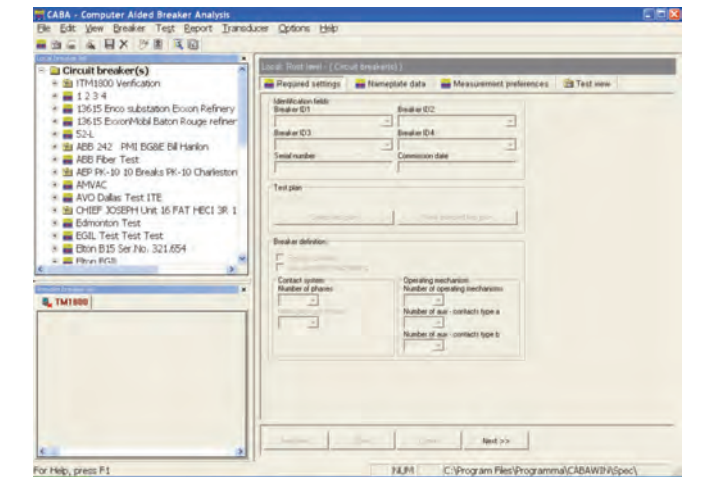

It is possible to quickly analyze the operation of a breaker and see if it is opening or closing in the proper amount of time and in some cases it is possible to see pass or fail. Being able to see pass or fail criteria involves entering limits into the breaker test plan before starting to testing the breaker

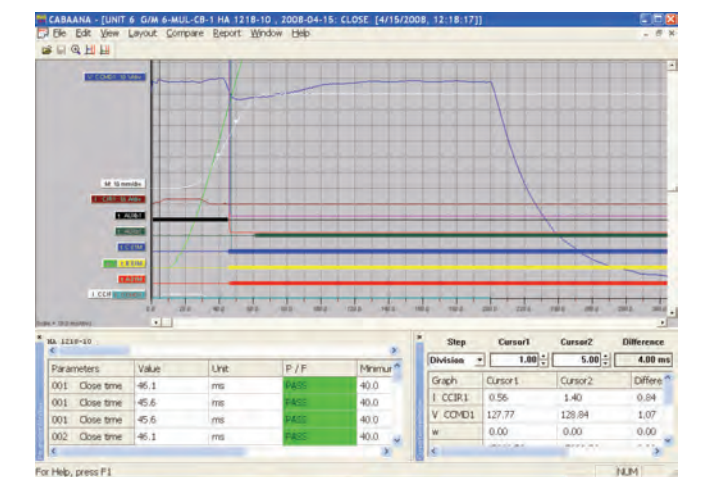

**MEGGER TEST INSTRUMENTS**

The following instruments are suitable for testing both MV and HV Breakers.



**B10E**

Power supply unit B10E is used to supply voltage to the circuit breaker coils and spring-charging motor during installation and/or field service. Since the high quality voltage available at the coil outputs is load independent, the power supplied resembles that encountered under normal operating conditions. Circuit breaker functionality thus remains virtually unchanged. The B10E enables circuit breaker functions to be tested easily at the specified voltage levels. Since the power supplied by the B10E is unaffected by load and is virtually ripple-free, it's ideal for minimum trip-voltage tests. The new easier-to-use design also simplifies B10E hookup.



**EGIL**

The Megger EGIL is an automatic timer and motion analyzer for medium- and high-voltage substation circuit breakers. EGIL incorporates features commonly found on more complex test systems, but is designed to be smaller, simpler to use and less expensive than other similar test sets. The size makes it attractive to smaller utilities and it is an ideal supplementary product for maintenance departments in larger power companies, and for testing contractors. It was designed specifically for breakers having only one main contact per phase and one operating mechanism. Main contacts and pre-insertion resistors are recorded and displayed simultaneously. Coil currents and signals at two auxiliary contacts are also

measured as standard. EGIL can be equipped with an analog channel for motion measurement (for example) and a serial port for communication with the CABA computer program. EGIL can be equipped with one extra analog input to make DRM measurement possible. EGIL is very easy to use, and multi-cable sets simplify on-site hookup.



**TM1600**

Different customers have different needs. There are many types of breakers, many types of troubleshooting procedures, many routine-testing philosophies, etc. What could be more natural than to use an instrument that can be adapted to all conceivable functionality/performance needs? The TM1600/MA61 functions efficiently in all types of switchgear environments, and thanks to its modular design it can be equipped with the

desired number of digital and analog measurement channels. Modules are available to measure analog entities such as motion, current, voltage, resistance and vibration. Sampling frequencies range up to 40 kHz. Software is also available to perform the sophisticated signal analysis needed to determine vibration trends. The TM1600/MA61 was designed from the start to facilitate routine testing, and this also applies to the CABA Win software used to analyze and administer test data.

The TM1600 circuit breaker analyzer measures a circuit breaker's timing cycle. The timing channels record closings and openings of main contacts, resistor contacts and auxiliary contacts. Since the timing channels are not interconnected, measurements of resistor contacts and series connected breaker chambers can be taken without having to disconnect them.

The TM1600 can be equipped with up to 24 time measuring channels as required by the user. When more than 24 channels are needed, several units can be connected together to get an unlimited number of measurement channels. Modular design also makes it easy to combine the system with the MA61™ Motion Analyzer for up to 6 analog channels.



**TM1800**

The TM1800™ is a unique instrument platform for circuit breaker maintenance, based on more than 20 years' experience with over 4,000 delivered breaker analyzers. The modular construction makes it possible to configure the TM1800 for measurements on all known types of circuit breakers in operation on the world market. The patented DualGround™ testing using the new DCM module makes testing safe and saves time by keeping the circuit breaker grounded on both sides throughout the test. The DCM module uses a measuring technology called Dynamic Capacitive Measurement. Timing M/R uses patented Active Interference Suppression to obtain correct timing and accurate PIR (Pre-Insertion Resistor) values in high voltage substations.

**HOW TO MOUNT A MOTION TRANSDUCER**

For many years, breaker contact motion (travel) has been considered one of the most important parameters for checking a breaker's interrupting capacity. Even though most types of breakers are accompanied by instructions that explain how to mount a motion transducer, these instructions are sometimes vague (or missing altogether). There is, therefore, a need for a few simple guidelines for selecting the right type of transducer and the location on the breaker where measurements are to be taken.

Ideally, a linear transducer should be used when the contact moves along a straight path. The transducer should be attached firmly enough to eliminate play and aligned in the direction taken by the operating mechanism rod. This is often impossible, however, and the next best thing is to select a shaft end on the gearing located beneath the breaking pole. Frequently a bolt has been screwed into this gearing, and its hole can be used. Drill a 6.1 mm diameter hole in the head of a bolt of the same size, and then drill a second hole from the side for a setscrew. This provides an excellent attachment fitting that can be used for a rotary transducer. Using a transducer fitting is by far the fastest way to attach a motion transducer.

The point selected for attaching the sensor probably does not move in the same direction as the breaking contact. To solve this problem, a conversion table can be prepared. This conversion table will enable CABA Win to present the contact's motion and speed.

**Two options are available:**

1. Write a formula based on the mechanical geometries of the attachment point and the contact.

or

2. Conduct a set of comparative 'once-only' measurements with the transducer connected to the most suitable and practical point.



If it proves impossible to obtain verified limit values for the breaker's closing and opening speeds, an alternative is to select a suitable attachment point and produce a "fingerprint" that can be used as a reference for the breaker in question. At the very least, this will enable any departures from present conditions to be detected.



Good universal attachment fittings are available for transducers. One is designated as a rotary transducer kit. If a particular type of breaker is tested frequently, it may be advisable to obtain a made-to-order tool that can be used to attach the transducer at the selected point. Don't forget to use a flexible coupling between the rotary transducer and the breaker shaft since any change in the position of the shaft that occurs over time can damage the transducer.

## DRM (DYNAMIC RESISTANCE MEASUREMENTS)

Programma, which is now part of Megger, began conducting practical DRM tests in 1989, and during the next few years several projects were undertaken together with manufacturers and customers. The objective was to find techniques suitable for everyday use. DRM procedures measure variations in contact resistance during breaker operation – not to be confused with static resistance measurement, which measures contact resistance when a breaker is closed and not moving.

DRM has a number of applications. On certain types of breakers DRM can be used to measure the shortening of arcing contacts. When breaker contact motion is measured simultaneously with resistance, the results can be used to determine the length of the arcing contact. In some cases, breaker manufacturers can supply reference curves for the type of contact in question.

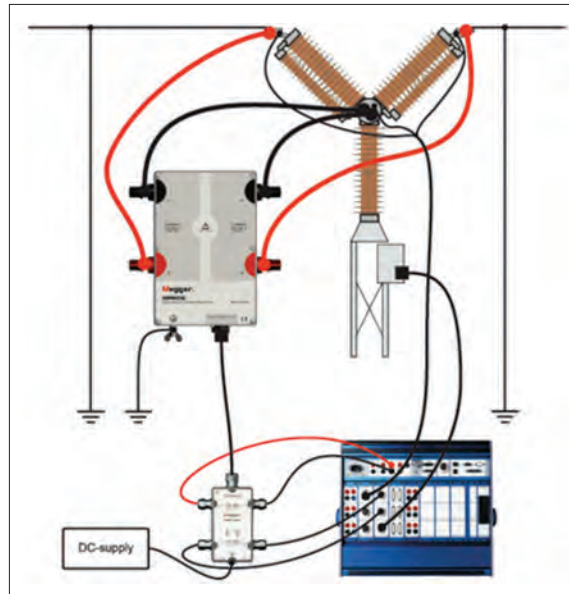

Things to remember when selecting DRM equipment

- High measuring current provides greater voltage drop, thereby improving accuracy and reducing noise problems.
- Higher sampling frequencies improve accuracy when measuring contact length.
- High resolution (12 or 14 bits) improves both accuracy and dynamic range.



## VIDAR

When a vacuum circuit breaker is commissioned or undergoes routine tests, it is very important to be able to ascertain whether or not the vacuum interrupter (VI) is intact before putting it back into operation. VIDAR makes it possible to check the integrity of the vacuum interrupter quickly and conveniently by means of the known relationship between the flashover voltage and the vacuum interrupter. A suitable test voltage (DC) is applied to the breaker, and the result is known immediately.



## ODEN

This powerful test system is designed for primary injection testing of protective relay equipment and circuit breakers. It is also used to test the turns ratio of current transformers attached to the bushings and for other applications that require high variable currents. The system consists of a control unit together with one, two or three current units. There are three versions of the current unit: S, X and H. The S and X current units are identical except that the X unit has an additional 30/60 V output. The H unit is rated for even higher current (20kA). This makes it possible to configure an ODEN AT system in a suitable way. All parts are portable, and ODEN AT can be quickly assembled and connected.

## MICRO OHMMETERS

Megger has been making micro ohmmeters for many years and its extensive range of products is designed to use high current for both static and dynamic resistance measurements. Some of the of the static "Ductor" products available from Megger are Mjolner, DLRO-10 and DLRO-200.

DRM is also a micro ohmmeter product and, with new technology, allows tests to be performed on breakers with two breaks per phase using a reasonable amount of equipment. With new technology the micro ohmmeters are light as well as reliable.



## References

- 1) Courtesy AL Power
- 2) Courtesy Waukesha
- 3) Courtesy of a Midwest Utility in OH
- 4) Courtesy Sacramento Fire Marshall Investigation 2001
- 5) Courtesy Areva Factory Cut-Away View of SF<sub>6</sub> Arcing Chamber
- 6) Reprinted from Megger DCM Module training document
- 7) Reprinted from Megger DCM Module training document
- 8) Reprinted from Megger DCM Module training document
- 9) Reprinted from Megger DCM Module training document
- 10) Reprinted from Megger TM1600 Training Document
- 11) Reprinted from Megger Dual Ground Marketing Document

**Megger**®